

Configuration Options on Standard Pre-Wired Harnesses

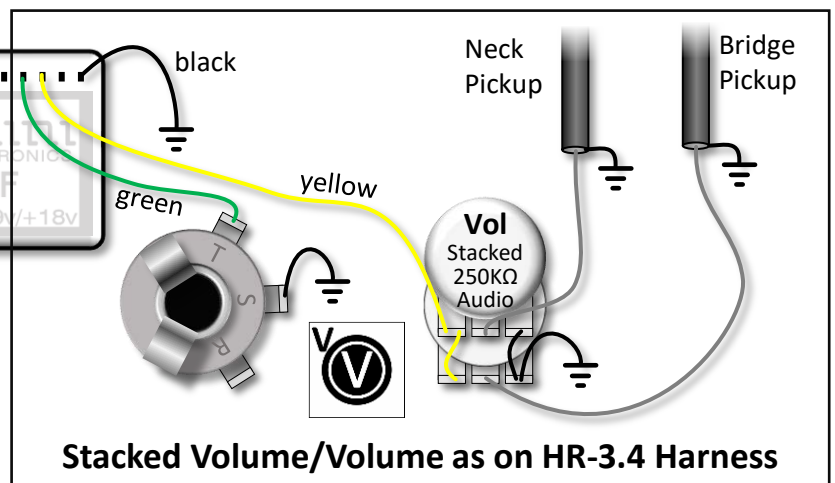
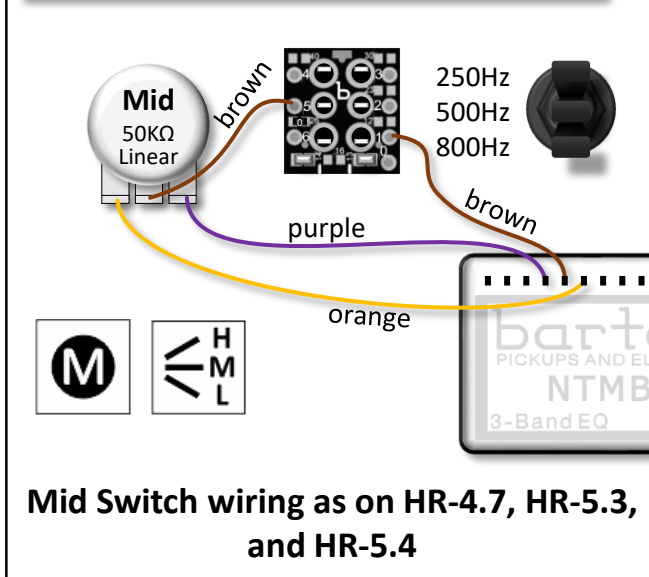
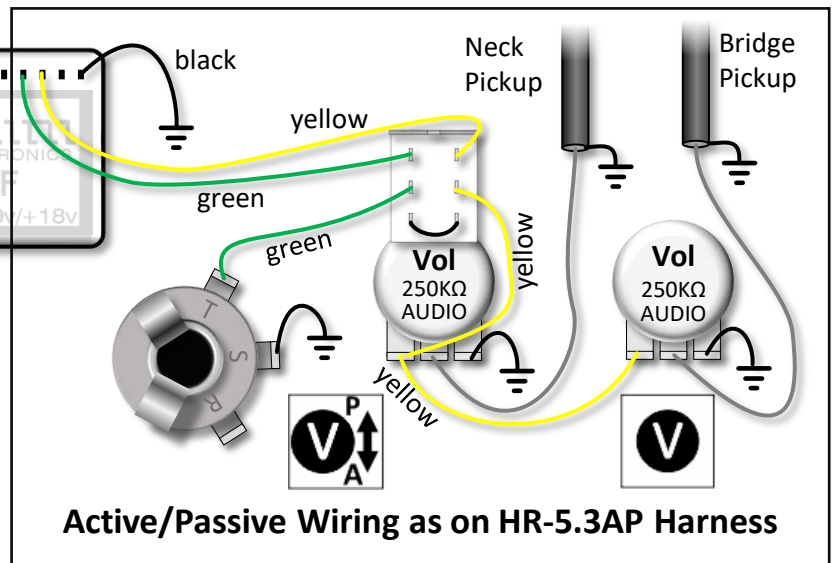
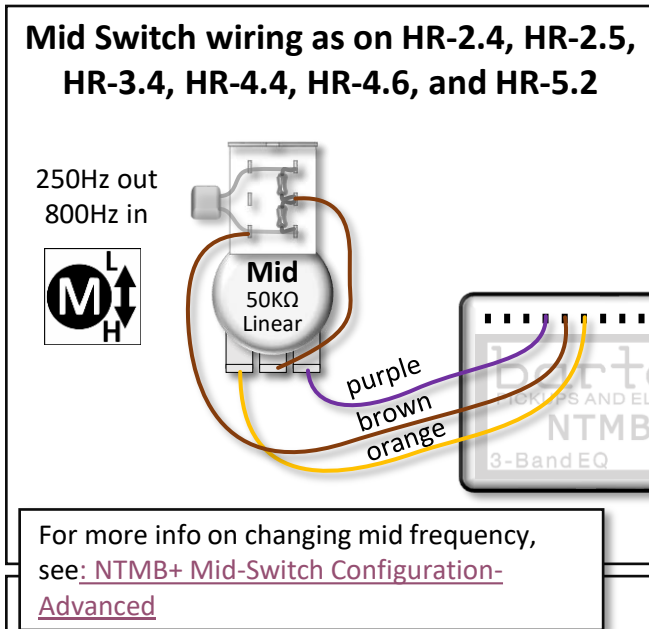
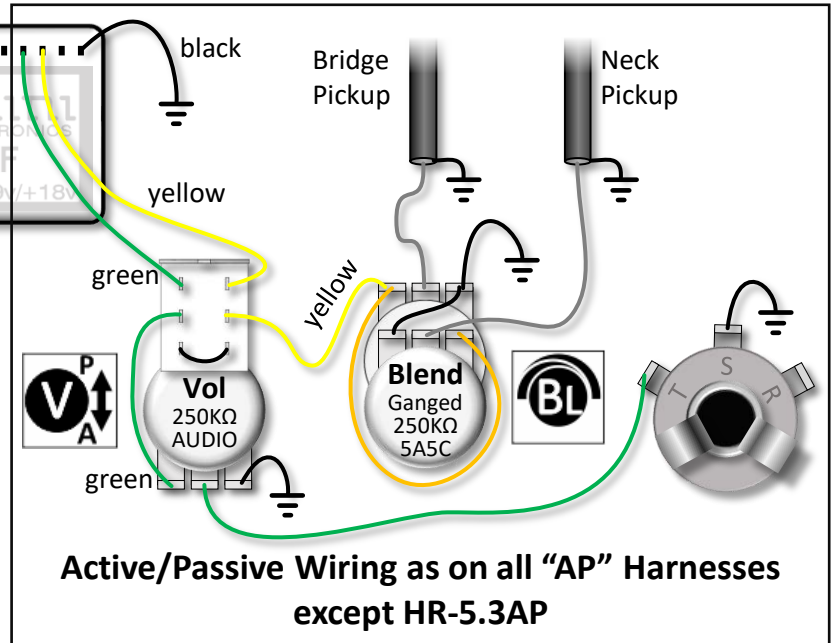
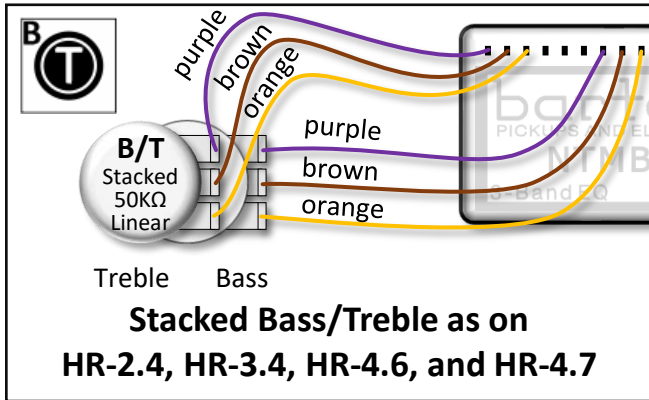

Ground – Connected to preinstalled bare wire.
 Connect to cavity shield if available. Also ensure bridge is connected to ground.